

COD. STRUTTURA STUFA 7014026 (BAFA)
EAN 8033123615044

METALLO

- BIANCO**
6914006
EAN 8033123614818
- SILVER**
6914007
EAN 8033123614825
- ROSSO**
6914005
EAN 8033123614801

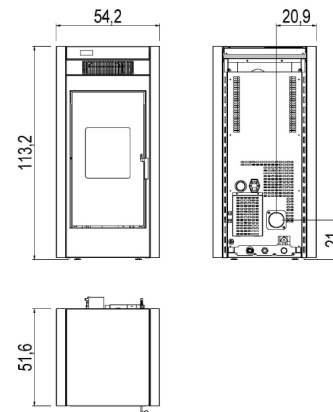

PLUS PRODOTTO



Collegamento all'impianto di riscaldamento



Protezione anti surriscaldamento



Braciere in ghisa



Sensore di temperatura acqua



Collegamento termostato esterno



Scarico fumi posteriore



Kit idraulico incluso



Maniglia anti ustione



Sensore di temperatura aria



Programmazione giornaliera settimanale



Ventilazione

DATI TECNICI

Potenza nominale	kW	15,4
Potenza ridotta	kW	4,4
Potenza utile all'acqua nominale	kW	13
Potenza utile all'acqua ridotta	kW	3
Rendimento nominale	%	92,1
Rendimento ridotto	%	95
Volume riscaldabile (min-max)	m ³	106 - 370
CO al 13% O ₂ nominale	%	0,011
CO al 13% O ₂ ridotto	%	0,04
Contenuto di polveri al 13% O ₂ nominale	mg/Nm ³	18
Capacità caldaia (H ₂ O)	l	14
Capacità serbatoio	kg	29
Combustibile		Pellet ø6
Consumo orario (min-max)	kg/h	0,90 - 3,40
Autonomia (min-max)	h	32,2 - 8,5
Assorbimento elettrico in accensione (max)	W	420
Assorbimento elettrico in lavoro (max)	W	120
Tensione di alimentazione e frequenza	V - Hz	230 - 50
Depressione canna fumaria	Pa	10
Diametro scarico fumi	mm	80
Diametro ingresso aria comburente	mm	50
Massa fumi (min-max)	g/sec	4,5 - 10,4
Temperatura fumi in uscita (max)	°C	145
Peso netto	kg	149
Peso lordo	kg	159

IMBALLO E STOCCAGGIO

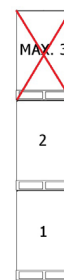
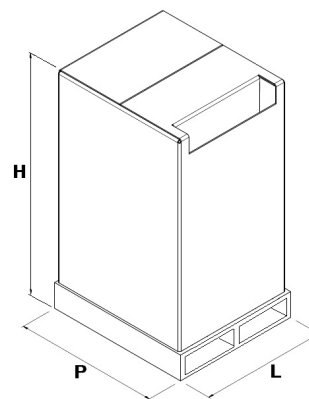

L (cm)	68
H (cm)	133
P (cm)	80

IMBALLO FINITURE

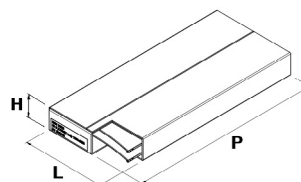

FINITURA	L (cm)	H (cm)	P (cm)
Metallo	54,5	12,5	114



EN 14785:2006



BlmSchV 2015



Regensburg



Bundesamt für Wirtschaft und Ausfuhrkontrolle (BAFA)

München

Stuttgart

Aachen