

DET12_{REV15}



DET12/DUET

AISI 316/L STAINLESS STEEL





Rubinetteria 3 fori con bocca di erogazione girevole

Three-hole mixer with swivelling spout

DESIGN
MARIO TESSAROLLO / DANIELA LORATO

 Portata aeratore 5 l/min / 1.3 gpm, risparmio idrico
Flow rate aerator 5 l/min / 1.3 gpm, water saving

MANUTENZIONE / MAINTENANCE

NON UTILIZZARE DO NOT USE		acido clorico e muriatico chloric and muriatic acid
		acido fluoridrico hydrofluoric acid
		ipoclorito di sodio chlorine bleach
UTILIZZARE TO USE		sapone a PH neutro neutral PH soap

Questi disegni sono proprietà di CEADDESIGN SRL s.u. pertanto non potranno essere utilizzati e/o comunicati a terzi, anche in forma parziale, senza preventiva autorizzazione. CEADDESIGN SRL s.u. si riserva il diritto di apportare modifiche ai disegni al fine di migliorare il prodotto.

CEADDESIGN SRL s.u. has the property rights on these drawings, therefore they cannot be used and/or transferred to third party, even in partial form, without any prior authorization. Furthermore CEADDESIGN SRL s.u. reserves the right to apply any change to these drawings in order to upgrade the product.

CEA

ceadesign.it

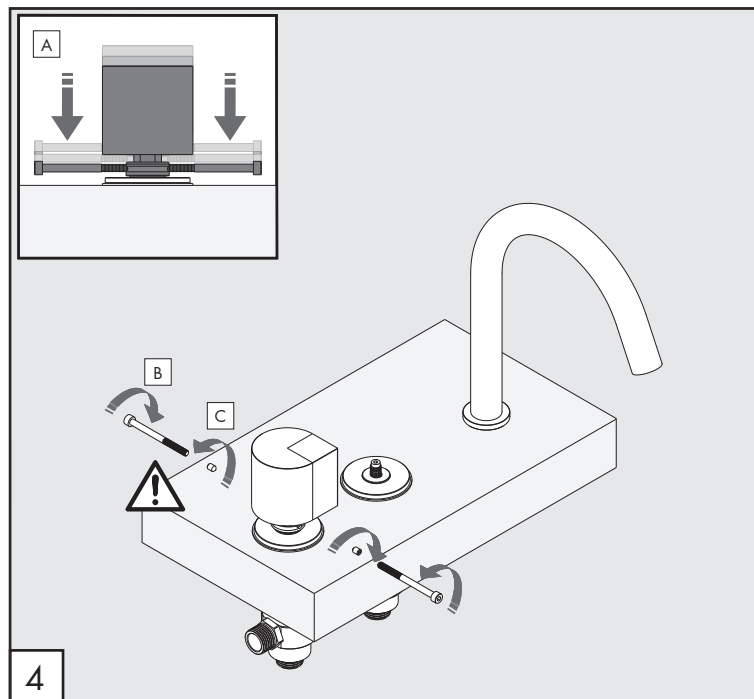
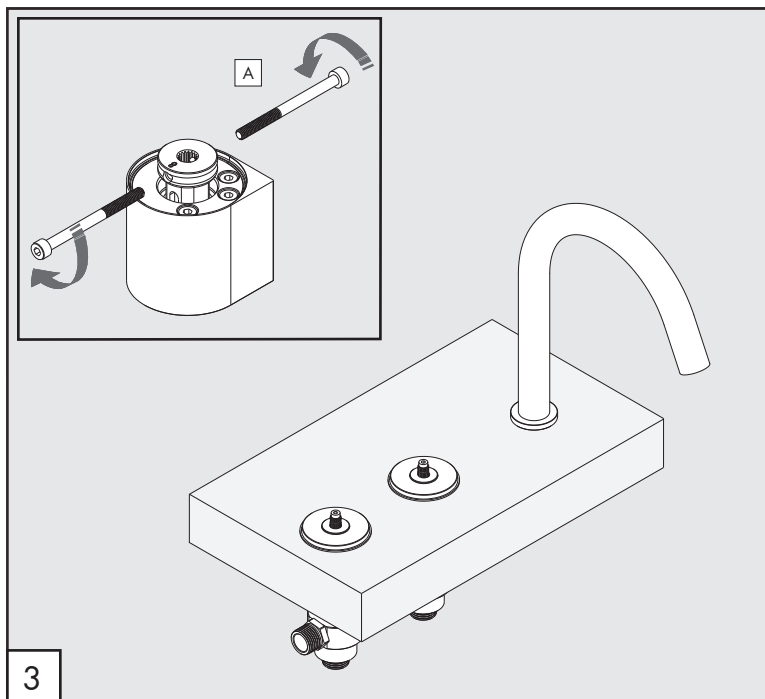
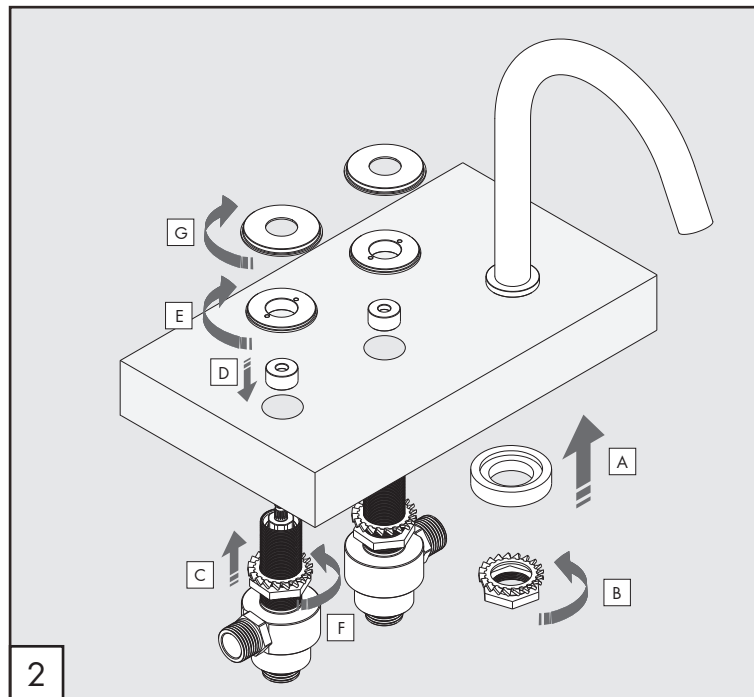
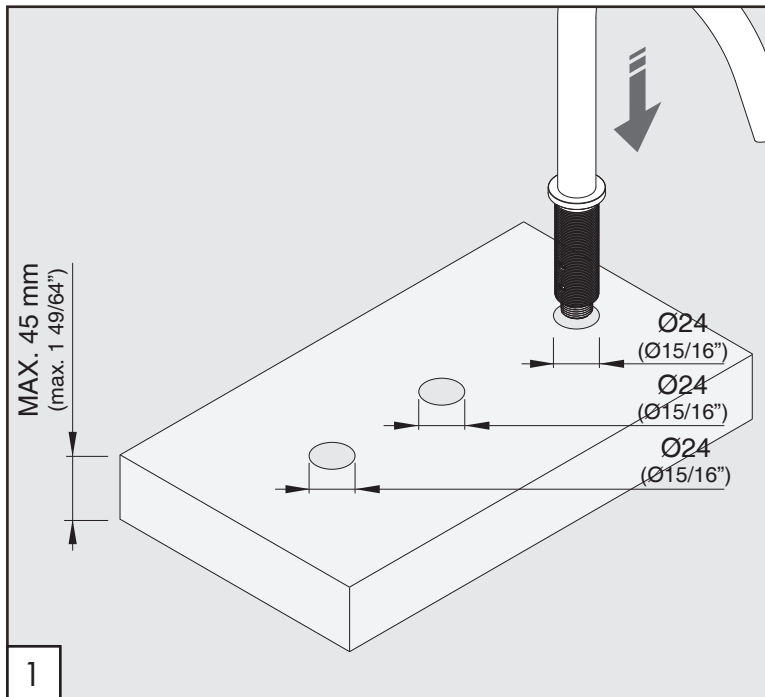

DET 12

_REV15

AVVERTENZE TECNICHE

Risciacquare bene le tubazioni prima del montaggio ed evitare sbalzi di pressione fra i raccordi d'acqua fredda e d'acqua calda. In caso di pressioni statiche superiori a 5 bar si raccomanda l'installazione di un riduttore di pressione per evitare danni alla cartuccia.

TECHNICAL WARNINGS

The pipes have to be rinsed thoroughly before installation. Avoid pressure differences between hot and cold water supply. Use of a pressure reducer when static pressure is higher than 5 bar to avoid damage of the cartridge.

TECHNISCHE WARNUNG

Spülen Sie die Leitungen vor dem Einbau und verhindern Sie Wasserdruckwechsel zwischen kalt und warm Wasserverbindungen. Wenn Wasserdruck größer als 5 bar ist, bitte reduzieren Sie den Systemdruck, um Beschädigung der Kartusche zu verhindern.

ADVERTENCIA TÉCNICA

Los tubos tienen que ser enjuagados a fondo antes de la instalación. Evitar grandes diferencias de presión entre las conexiones de agua caliente y fría. En caso de presión estática mayor de 5 bar, se recomienda el uso de un adaptador de presión para evitar daños en el cartucho.

ADVERTISSEMENTS TECHNIQUES

Rincer les tuyaux avant l'installation. Eviter des grandes différences de pression entre l'eau froide et chaude. En cas de pressions statique de plus de 5 bar, nous vous recommandons d'installer un réducteur de pression pour éviter des dommages à la cartouche.

TEMPERATURA D'ESERCIZIO / WORKING TEMPERATURE

🌡️ max. 70 °C
max. 158 °F

Le portate indicate sono alla pressione consigliata di 3 bar
The indicated flow rates are at the recommended pressure of 3 bar

AERATORE IN DOTAZIONE / AERATOR INCLUDED

🌊 **Aeratore montato / Mounted aerator**
5 l/min / 1.3 gpm

AERATORI SU RICHIESTA / AERATORS ON DEMAND

🌊 Conforme agli standard LEED / Compliant with LEED standards
1,9 l/min / 0,5 gpm

🌊 Conforme agli standard LEED / Compliant with LEED standards
3,8 l/min / 1 gpm

CEQ

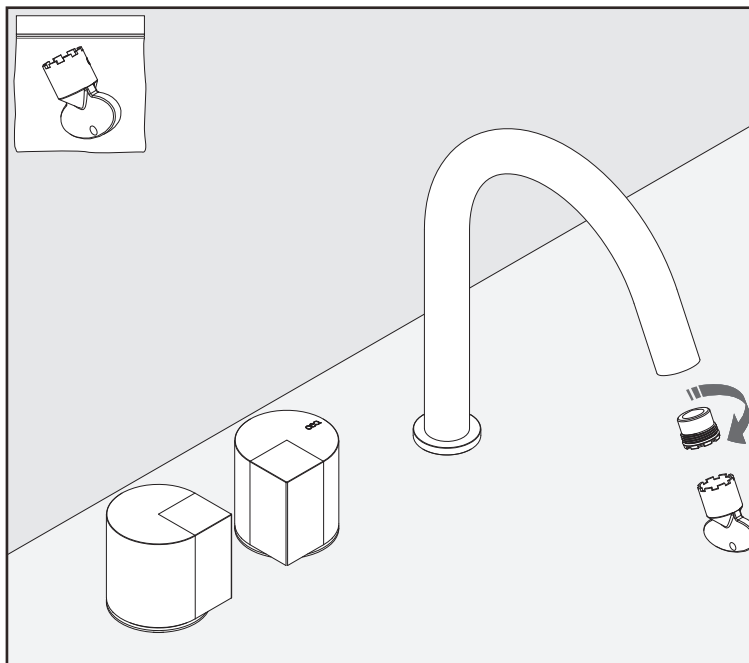
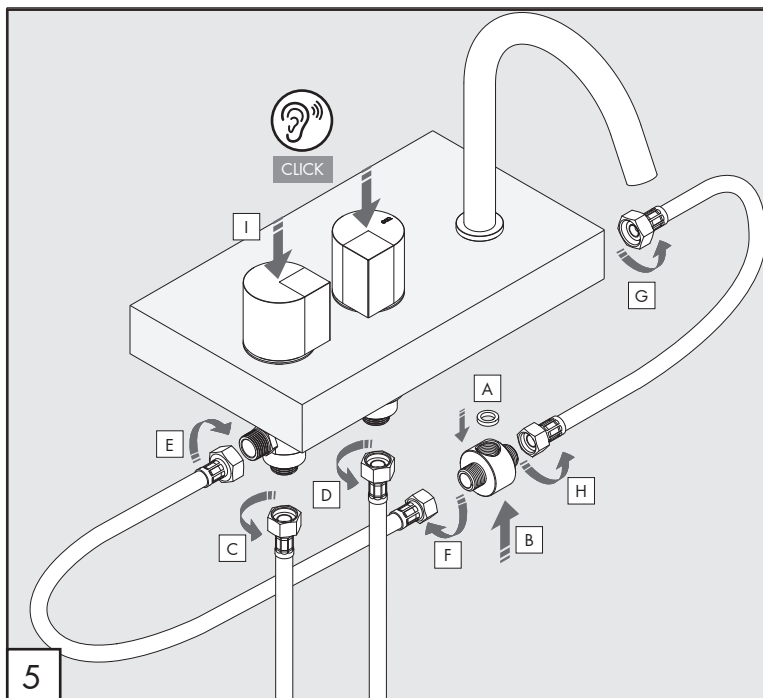

DET 12

_REV15

AVVERTENZE TECNICHE

Risciacquare bene le tubazioni prima del montaggio ed evitare sbalzi di pressione fra i raccordi d'acqua fredda e d'acqua calda. In caso di pressioni statiche superiori a 5 bar si raccomanda l'installazione di un riduttore di pressione per evitare danni alla cartuccia.

TECHNICAL WARNINGS

The pipes have to be rinsed thoroughly before installation. Avoid pressure differences between hot and cold water supply. Use of a pressure reducer when static pressure is higher than 5 bar to avoid damage of the cartridge.

TECHNISCHE WARNUNG

Spülen Sie die Leitungen vor dem Einbau und verhindern Sie Wasserdruckwechsel zwischen kalt und warm Wasserverbindungen. Wenn Wasserdruck größer als 5 bar ist, bitte reduzieren Sie den Systemdruck, um Beschädigung der Kartusche zu verhindern.

ADVERTENCIA TÉCNICA

Los tubos tienen que ser enjuagados a fondo antes de la instalación. Evitar grandes diferencias de presión entre las conexiones de agua caliente y fría. En caso de presión estática mayor de 5 bar, se recomienda el uso de un adaptador de presión para evitar daños en el cartucho.

ADVERTISSEMENTS TECHNIQUES

Rincer les tuyaux avant l'installation. Eviter des grandes différences de pression entre l'eau froide et chaude. En cas de pressions statique de plus de 5 bar, nous vous recommandons d'installer un réducteur de pression pour éviter des dommages à la cartouche.

TEMPERATURA D'ESERCIZIO / WORKING TEMPERATURE

 max. 70 °C
 max. 158 °F

Le portate indicate sono alla pressione consigliata di 3 bar

The indicated flow rates are at the recommended pressure of 3 bar

AERATORE IN DOTAZIONE / AERATOR INCLUDED

Aeratore montato / Mounted aerator
5 l/min / 1.3 gpm

AERATORI SU RICHIESTA / AERATORS ON DEMAND

 Conforme agli standard LEED / Compliant with LEED standards
 1,9 l/min / 0,5 gpm

 Conforme agli standard LEED / Compliant with LEED standards
 3,8 l/min / 1 gpm

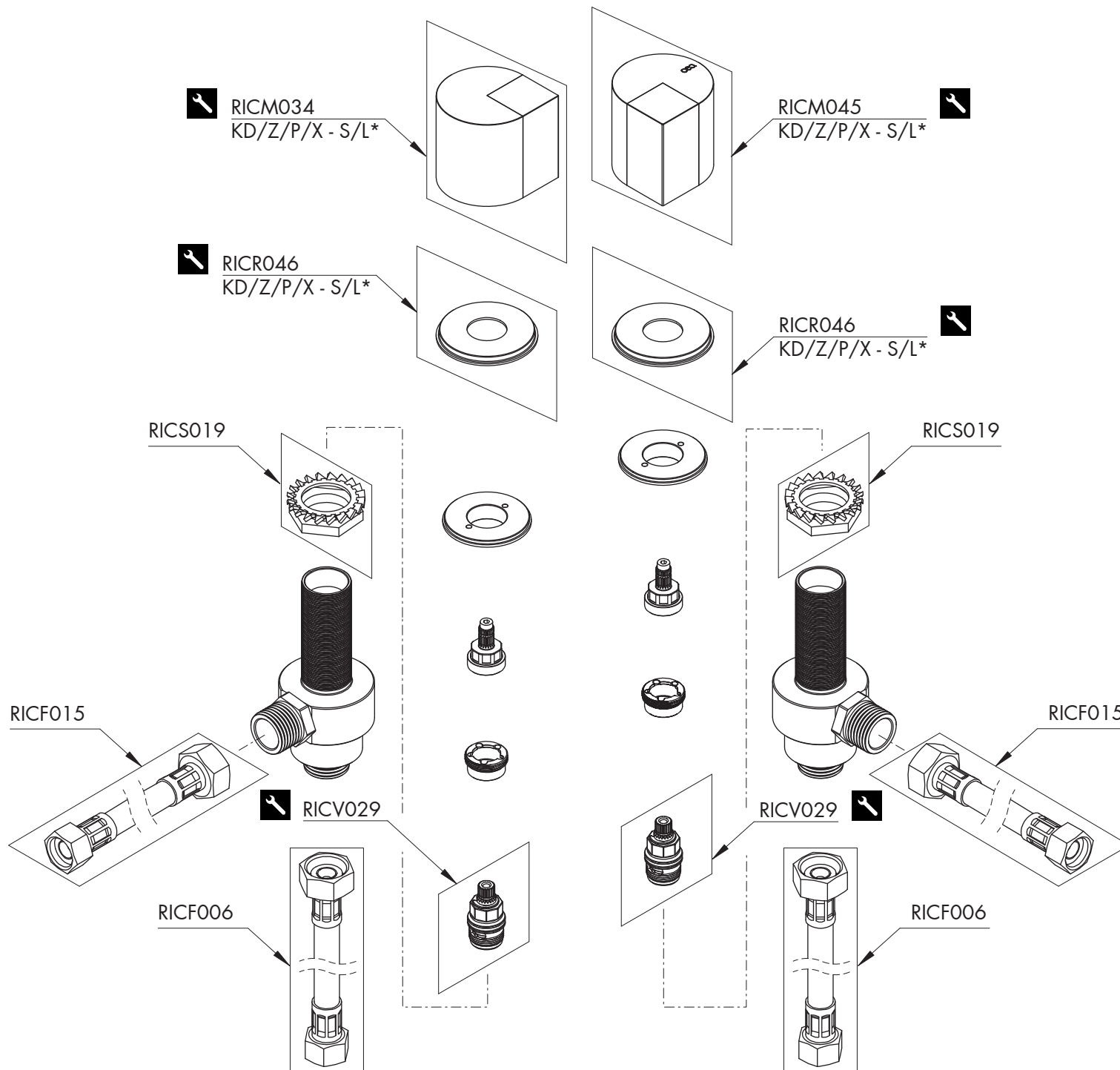

RICAMBI / SPARE PARTS

RICF006	Flessibile / <i>Hose</i>
RICF015	Flessibile / <i>Hose</i>
RICM034	Maniglia / <i>Handle</i>
RICM045	Maniglia / <i>Handle</i>
RICR046	Rosetta / <i>Rosette</i>
RICS019	Kit di fissaggio / <i>Fixing kit</i>
RICV029	Vitone / <i>Shut-off valve</i>

LEGENDA / LEGEND

ICONE / ICONS

 Utensile incluso nel ricambio
Tool included in spare part

FINITURE / FINISHES

*S finitura satinata / *satin finish*

FINITURE SPECIALI / SPECIAL FINISHES

KD black diamond
 Z bronzo / *bronze*
 P rame / *copper*
 X light gold

RICAMBI / SPARE PARTS

RICA001	Aeratore / Aerator	5 l/min / 1.3 gpm
RICS003	Kit di fissaggio / <i>Fixing kit</i>	
RICT005	Raccordo / <i>Fitting</i>	

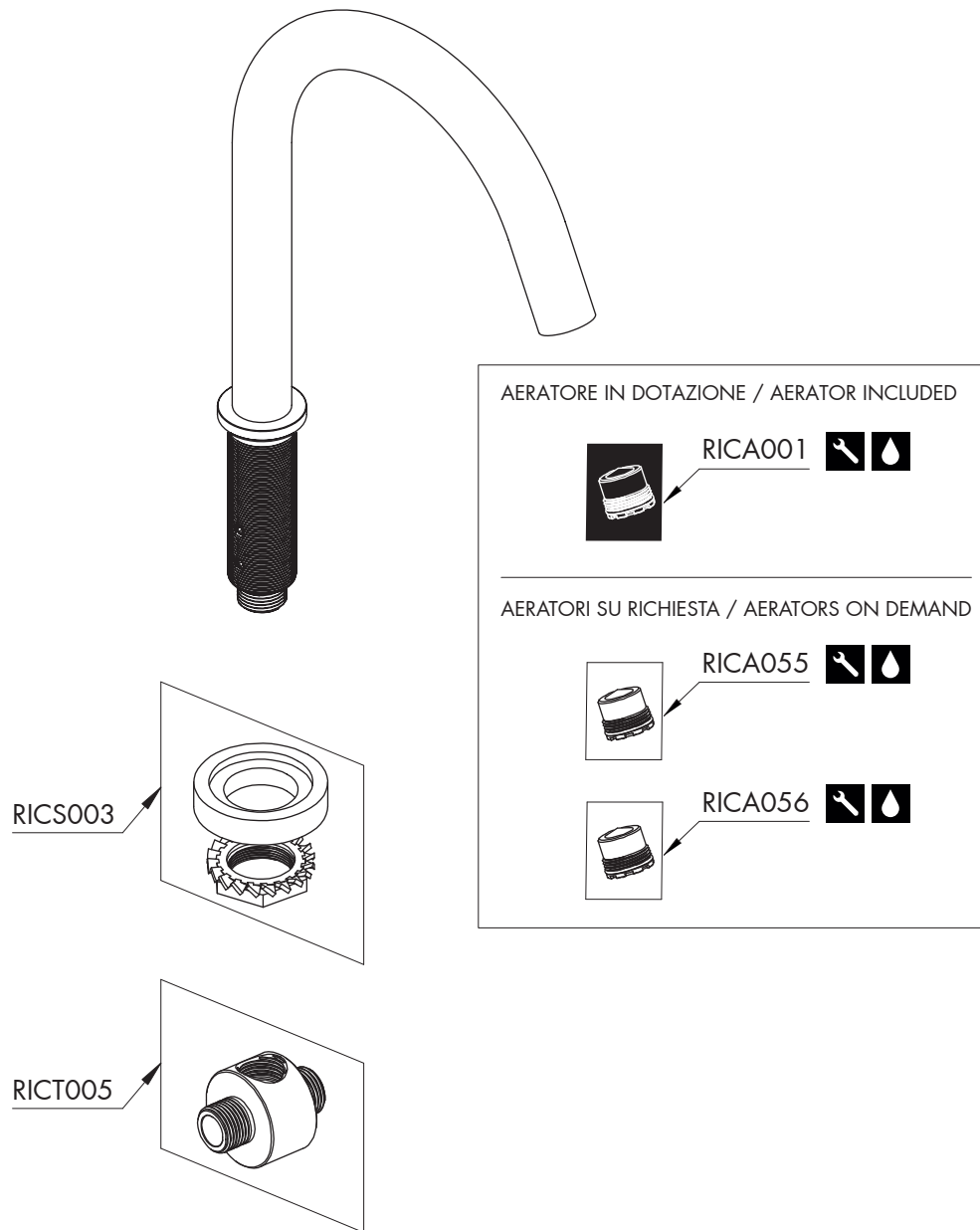

AERATORI SU RICHIESTA / AERATORS ON DEMAND

RICA055	Aeratore / <i>Aerator</i>	1,9 l/min / 0.5 gpm
RICA056	Aeratore / <i>Aerator</i>	3,8 l/min / 1 gpm



LEGENDA / LEGEND

ICONE / ICONS

-  Aeratore a risparmio idrico, utilizzabile per lavabo
Water saving aerator, suitable for wash-basin
-  Utensile incluso nel ricambio
Tool included in spare part